



9550 MP3000

**Credit Card
Bill & Coin Vend
Station**

Admin Manual



Jamex - “The Payment Method People”

Since 1981, Jamex has developed vending technology for a variety of applications. We look forward to assisting people like you with ongoing innovations in revenue generation through vending. Jamex is a manufacturer who believes in service. Should you have any questions concerning your Jamex 9550 MP3000 or other Jamex Vending Systems, please call your authorized Jamex dealer, or Jamex customer service at 800-289-6550, or visit our web site at www.jamexvending.com.

Your Partner For 40 + Years

Copyright, December 2023 by Jamex, Inc.

Table Of Contents

Administrator Manual

Introduction	1
Installation and Setup	
Unpacking The Vend Station	3
Physical Mounting	3
Electrical Installation	3
Setting Two Line Display Contrast	3
Network Requirements	4
Connecting To a Network	4
Programming your Vend Station	
Using The “Web Tool” To Program The Vend Station	5
Importing- Exporting a Configuration File	6
Manually Programming the Service Modes	7
Setting a Price For a Letter Sized B/W Copy	8
Configuring Credit Options	9
Checking For a Firmware Update	10
Loading Change	10
Load Change Mode	11
Directly Loading Change Tubes	11
Setting The Tube Reset Count	11
Reset Tube Meters	12
How Some Changers Handle Redundant Tubes	13
Dead Tube Inventory	13
Auto Tube Sense	13
Jamex Automated Reporting Software (Optional)	14
Jamex automated Reporting Software Requirements	15
Jamex Free Email Server	15
Customer Selected Email Server	15
Importing Email Settings	16
Cashing Out The Vend System	
Removing Cash	17
Removing Change From the Change Tubes	18
Retrieving the Cash Meters	19
USB-CSV Meter Exoet	20

Reconciliation the Cash Meter Totals With the Cash On Hand

Cash Totals	21
Cash on Hand	21
Negative Tube Difference	22
Positive Tube Difference	22
Alternative Method Using a Predetermined Tube Meter	22
Changer With a Removable Cassette	23
Changer With a Non Removable Cassette	23

Detailed Meter Descriptions

Session Meters	24
Life Meters	24
Cash Meters	24
Reading the Meters	24
Reset Session and Cashout Meters	25

Maintenance and Troubleshooting

Cleaning the CoinCo Bill Acceptor	27
Bill Acceptor Issues	27
Cleaning the Apex 7400	28
Apex 7400 Error Codes	29
Cleaning the Coin Changer	29
Clearing Coin Jams In a Three Tube Changer	30
Clearing Coin Jams Five Tube Changer	31
Payout Section Problems (Three Tube Changer)	32
Clear a Jam In The Cash Box Chute	33
Replacing Paper in Optional Receipt Printer	33
PC Communication Issues	34
Copier Errors	35
Power Problems	35

Complete List Of Service Mode Settings 36

Diagrams

Jamex 9550 Series Vend Station Full Exterior Layout	43
Jamex 9550 Series Vend Station Interior Layout	44
Cover Pan And Main Board Connector Locations	45

Service Mode Layouts

Settings Mode Layout	46
Meter Mode Layout	47

Introduction

Thank you for choosing a Jamex system. Jamex. This manual provides instructions for operating and maintaining your Jamex 9550 MP3000. Please review this manual completely before setting up the system, and keep this manual available for you and your technician. For further assistance contact Jamex Customer Support at 800-289-6550 or email us: support@jamexvending.com

Features of Your Jamex Model 9550 MP3000:

Jamex Vending Systems are sturdy, compact units designed to allow you to create and monitor a revenue stream using your existing office equipment. Your Jamex Vending System includes the following features:

- Accepts major credit cards using tap, chip or mag stripe.
- Card prices can be adjusted in 1 cent increments up to 80.00.
- Three programmable preset hold amounts and an option to choose a custom hold amount.
- Accepts any combination of nickels, dimes, quarters, and dollar coins as well as 1, 5, 10, and 20 dollar bills (depending on model).
- Cash deposits of up to \$80.00 can be held in escrow.
- Cash prices can be adjusted 5 cent increments up to \$80.00.
- Electronic coin validation for detection of slugs and foreign coins.
- Jamex's "Change Checker™" technology that guarantees enough change is available for return in coins when a bill is used.
- Over \$30 in self replenishing change storage.
- Bypass key to allow staff and technicians copier access without cash.
- Enhanced bypass mode to set a cash value or time limit that keeps the vend station in bypass without leaving the key in the bypass lock.
- Two line display that gives instructions and credit balance to the patron and provides reconciliation data to the administrator.
- Sturdy steel textured quartz white epoxy powder coat finish housing.
- Programmable features include:
 - Price per copy, scan, fax or print (depending on copier model)
 - Custom messages
 - Maximum allowable deposit (escrow) bill and card values
 - Programmable per-authorization amounts
 - Minimum value of credit card transaction
 - USB port for the importing/exporting of meters and settings.
- Network connection used for validation of credit cards, firmware updates, optional Jamex Automated Reporting Software, and advanced diagnostics.

Optional Features:

- Extended Warranty
- USB JPC interface for connection to a host PC for interfacing with vending software.
- Can be used with a cellular modem for processing credit transactions.
- Receipt printer for receipts of credit card transactions.
- High capacity changer for even greater coin payout capacity.
- International currency capability (call for availability)
- CS-1 Support: Mounting system providing security for front cassettes, work area for the patron, and a small footprint.
- 57 Base: Free-standing base
Note: Units ordered with the base will arrive with the base already attached for easier installation on site.
- Jamex Automated Reporting Software: Emails meter/event reports to a site's email addresses.

All Jamex products come with:

- A one year repair or replacement warranty on parts shipped overnight.
Note: Return shipping is not included.

The full family of Jamex products includes:

- Multi copy coin only systems
- Multi copy coin & bill vending systems
- NetPad Touch Swipe Credit Card Solution
- Mobile Pay NetPad Touch Credit Card Solution
- True Count remote digital copy counter
- Print vending systems for computers and computer networks
- System 7000 Stored-Value magnetic stripe card system
- 8200 Series Card Dispenser/Revalue Stations
- Compatible mounting systems and stands
- Copy Card Admin Software (CCAS)

Additional information available at jamexvending.com

Installation and Setup

Unpacking The Vend System:

The following items are included in your Jamex 9557 MP3000 shipment:

- Model 9550 MP3000 vending unit
- Quick Start Guide, Admin and User manuals, and copier install guide
- Power supply
- 6 keys; 2 keys each for the door, bypass lock, and cash drawer.
- Interface cable (if applicable)
- USB cable for Jamex's JPC connection (if applicable)

Boxed Separately:

Lane 3000 credit card reader and its mounting hardware

Physical Mounting:

Your Jamex Vend System may be mounted on one of the available stands manufactured exclusively for Jamex or it can be mounted to a wall, or cabinet. If securing to a wall or cabinet, route all the cabling through the cabinet through the hole in the back of the vend station or through the area at the bottom of the housing next to the hinge.

Ensure that the cables cannot be caught or pinched.

Electrical Installation:

Always connect the power supply to the vend station first before connecting the power supply to the wall. There is a round four pin DIN connector which connects to its mating plug. If the vend station is mounted on a base, the mating plug is located under the base. If the base is not attached, the mating plug is located inside the door of the vend station. Next, connect the other end of the power cable to an 110 VAC grounded outlet. International power supplies ship with connections specific for your regions voltage.

Attention: A poorly grounded or overloaded outlet will severely impact the vend system's performance. A dedicated outlet is recommended.

Please refer to the Point-to-Point Wiring Diagram, included with your vend station, for the details on connections to your specific copier.

Setting Two Line Display Contrast:

The contrast of the 2-line display on the top of the vend station can be adjusted. Let the unit fully boot before adjusting. Locate the contrast trim pot near the six button array on the main board. See pages 44 and 45 for the exact location. Turn the trim pot clockwise to adjust the display darker and counter clockwise to adjust the display lighter.

Network Requirements:

A full time network connection is required. For security reasons all network communication is initiated by the vend station. This means there are no open ports available for someone to connect to.

The network connection will allow for

- Processing credit card transactions
- A one time remote activation of the credit card reader
- Firmware updates, upgrades or reconfiguration
- Sending email reports using the optional Jamex Automated Reporting Software
- Advanced diagnostics performed by Jamex engineers

Note: When networking your vend station, Your site will need to allow inbound and outbound TCP traffic to Jamex's server as well as the credit card's server on ports 22, 80, and 443. If using reporting, add your email server's port. If you're using the Jamex email server, it uses port 465.

Connecting To A Network:

- Locate the network port connector hanging inside the Jamex vend station beneath the main board (page 45) and connect a network cable to this port, then connect the other end to one of your network ports.
- The MAC address may not be displayed until a live connection is made. Navigate through the service modes to "Network Settings" to view the MAC address if needed by IT. See pages 7 and 37 for details.
- The Jamex Vend Station has DHCP set to “ON” by default. If your site is using a DHCP server, no other settings are required. If manual configuration is needed, the IT staff should review the “Using the Web Tool” and CSV import on pages 5 and 6. Those steps describe how to import the desired network settings.
- Verify that the vend station has network access by starting and stopping a Remote Support Session.
 - Locate the remote support button’s pin hole on the right side of the main board’s cover pan (pictured on page 45).
 - Press the remote support button by pushing a paperclip or pen through the pin hole.
 - A “Support Session ID” is displayed.
 - Push the button again to end it.

Remote Support
Session: 1234

Note: If port 22 is blocked, a session ID is displayed but Jamex support will not be able to see it. Consult with your IT staff to be sure the vend station can reach the internet on ports 22, 80 and 443.

Programming Your Vend Station

Most settings can be programmed manually but some will need to be imported. Use the Web Tool to create a configuration file with all your settings. This file can be used to program several vend stations.

Using the “Web Tool” To Program The Vend Station:

An instructional video titled “Using The 9550 Web Tool” is also available in the support section at jamexvending.com. First you will need to know your firmware version.

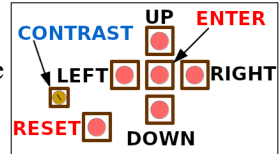

- Open the vend station, quickly press and release the “Enter” (center) button on the board.
- The Jamex display will scroll the current firmware type and version as well as the board's serial number.
- Note the firmware and press “Enter” again.

FW: scrollfw ver ←
S/N: Z01234567

- Connect a FAT 32 formatted USB drive to a PC with an internet connection.
- Go to jamexvending.com and in the support section, select the “9550 series Web tool”.
- Click on your firmware version and select the features from the list displayed. Then click “Next”. **Note:** Purchased options are not enabled here.
- Drop an exported config file for editing at the bottom of this page.

A screenshot of the JAMEX web tool interface. The page has a blue header with the JAMEX logo. Below the header are three tabs: Firmware, Features, and Settings. The Settings tab is active. The main content area has a blue background and contains a form with the following sections: Prices, Copy, Cash, and Settings. The Cash section has four rows: Small B/W, Large B/W, Small Color, and Large Color, each with a text input field containing '00:10'. The Settings section is at the bottom and is currently empty.

- Click an option to change.

Note: When keying in a password be sure there is a “0” after it.

Example: mypassword|0. During import, the 0 changes to a 1. The password will no longer be displayed as plain text when viewing the file.

- When done editing, click “Export” to save the new file to your PC.
- Cut and paste the file to the root directory of your USB drive.
- Disconnect the USB drive from the PC.
- Import the configuration file as shown on the next page.

Note: The web tool can be slightly behind firmware changes. Instead of using the web tool, You may need to export your current configuration file and edit the CSV with a spreadsheet program.

Importing / Exporting a Configuration File

- To import a file, Insert a FAT 32 formatted USB drive containing the CSV configuration file in the root directory, into one of the USB ports on the left side of the vend station's main board (page 45).

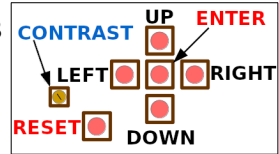

- Press and hold the “Enter” button for 5 seconds.
- Use the “Up” or “Down” buttons navigate to Import/Export.

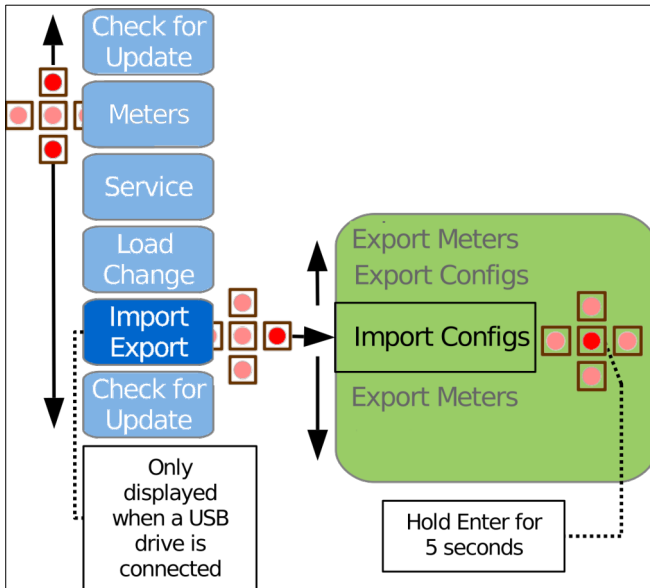

- Use the “Right” button to enter the “Import/Export” sub menu.
- Use the “Up” or “Down” button to navigate to the “Import or Export Configs” options.
- Press the “Enter” button for 5 seconds while on the "Import Configs" or to export the configuration, hold "Enter" button on Export Configs. When exporting remember that any configuration file already on the USB drive will be overwritten.
- Wait until the unit exits service modes before removing the USB drive.

Note: An exported configuration file can be edited with the Web Tool or a spreadsheet program. If using a spreadsheet program for editing, be sure to keep the CSV (comma separated values) format and watch that auto correct does not change the format of any of the fields.

Manually Programming The Service Modes

There are several service mode settings available to help you configure the vend station to suit your site's needs. For this reason we can not include a detailed step by step set of instructions for programming each setting. The full list of options can be found on pages 36 — 42. The “Settings Mode Diagram” on page 46 shows each settings location.

The section below walks you through two service mode operations, checking for an update and setting the price of a B/W copy. This will give you the feel of navigating the service modes that you can apply to programming other settings. There are also instructional videos in the support videos section at jamexvending.com. The videos "Setting Prices and "The Control Panel" show some of the same steps listed here.

Service Mode Navigation

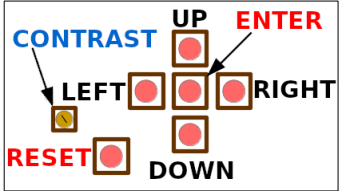
Buttons	Service Mode Navigation & Menu Options	
Right & Left	Navigate menus, move into or throughout a setting to change values.	<p>These buttons are located on the 9550's main board (see page 45).</p> 
Up & Down	Navigate menus, change individual characters or numbers or select from preset options.	
Enter	Saves a setting or completes an action	
Reset	Exits service modes. (Settings must be saved by pressing enter first.)	

Feature Option	Setting Description
On	1. Vended Feature and its prices are displayed. 2. A Vend Station feature is enabled.
Off	1. Vended feature and its prices are not displayed. However if a charge signal is sent for that feature from the MFP, it will be charged from existing credit. 2. A Vend Station feature is disabled.
Restrict	Vended feature does not display and it's price is set as high as possible to stop patrons from using that feature.
Free	Vended feature is displayed as complimentary and no funds are deducted when it is used.

Setting a Price For a Letter Sized B/W Copy

Your board may only connect to a PC or an embedded application. Those devices control pricing so it would not be displayed here.

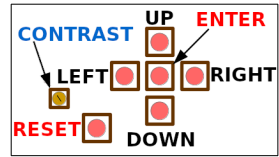

- Press and hold the “Enter” button on the main board for five seconds to enter service mode.
- The display shows "Meters". Press the “Down” button once to display “Service”.
- Press the “Right” button four times. Each press of the right button will display a different menu item. “Prices”, "Cash", “Copy”, and the “B/W Small” price setting option last.

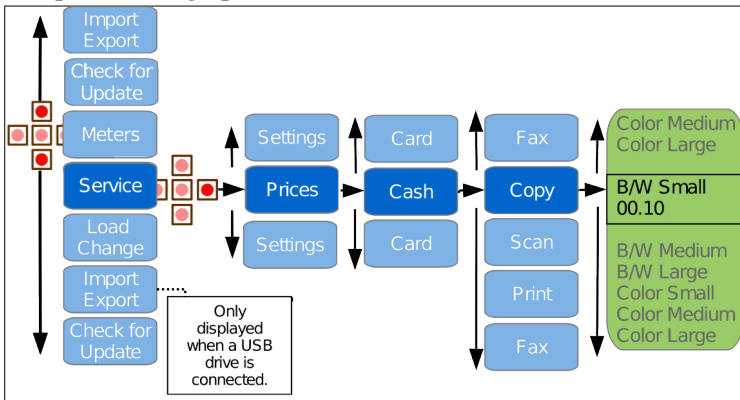

- Press the “Right” button once more to edit the current price.
 - Press the “Right” or “Left” buttons to select the specific digit to edit.
 - Press the “Up” or “Down” buttons to change that digit's value higher or lower.
 - Press the “Enter” button to save the current value.
 - Use the “Up” or “Down” button to select other prices to edit or press the “Left” button to go back to “Copy”.
 - Press the “Up” or “Down” buttons to select another feature like “Print”, “Scan” or “Fax” and then use the “Right” button to enter its price menu.
- Note: The functions available for vending vary by copier model.
- Press the “Reset” button to exit the service modes.

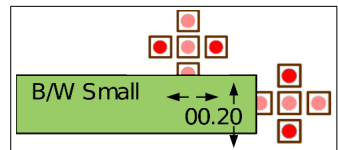

Note: If you do not want to charge extra for larger paper sizes, Match those prices to the "Small" price. A zero price will give free pages.

Configuring Credit Options

Location of the Credit Options in the service modes and their defaults can be found on page 38.

Quick Pay Buttons 1 – 3

On the credit card reader's home screen there are four quick pay options. The first three values can be set to custom values. These values must be whole dollar amounts (no cents) and can be as high as 80. These are set in the same way the prices are set.

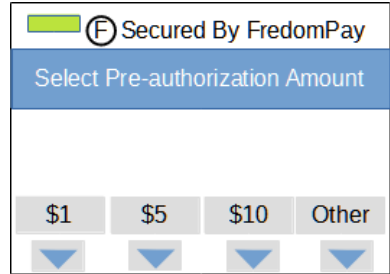

Credit TX Timeout

This is the length of idle time allowed before the credit transaction is automatically ended. This is a security feature to protect a patron that has walked away without ending their transaction. A shorter duration is better in a busy environment. A longer duration may be OK for some sites.

Credit Over Cell

An optional cellular modem can be purchased to allow credit card transactions to be processed through a cell network. Your site is responsible for setting up their cell service provider.

Note: Even with the "Credit Over Cell" option set to "On", All other network functionality is still done through the LAN port (see page 45). You will need a network cable connected for the following functions.

- Activation of the credit card reader
- Updating firmware
- Purchased firmware reconfiguration
- Support sessions for advanced troubleshooting
- Using the optional reporting feature (Jamex Automated Reporting Software).

Minimum Charge

The lowest value that can be entered manually via the reader's keypad is \$0.10 but a lower value can be charged. A minimum can be set to discourage patrons from using a credit card for small 1 page jobs.

For example: A \$0.50 minimum is set and the card prices are \$0.10 per page. When a 5 page or lower job is run, their card is still charged \$0.50. Once the job is at or over the minimum charge, pages are charged per page from there. A 6 page job would cost \$0.60 and a 1 page job would be 0.50. The remaining 0.40 of the 1 page job will be tracked to the Unapplied Credit meter.

Checking for a Firmware Update

You should always check for a firmware update before putting your vend station in service. New enhancements and features may have been implemented as well as modifications to adjust to changing technology. Before you can check for an update the vend station will need to be connected to a network (page 4). A message of “No update found” can also be displayed if there isn’t a connection to the Jamex server. For this reason you’ll need to verify a server connection by starting a support session first. Those steps are also found on page 4.

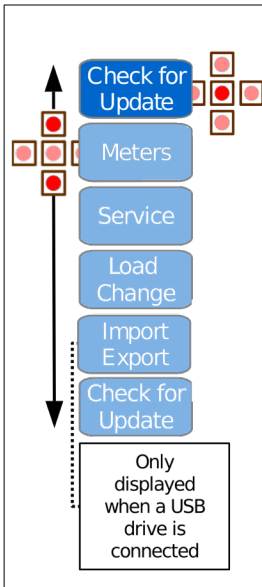

- Power down the copier.
- Press and hold the “Enter” button for five seconds.
- The display shows "Meters". Press the “Up” button once or the “Down” button three or four times to get to the “Check for Update” option.
- Press and hold the “Enter” button for five seconds and release to check for an update.

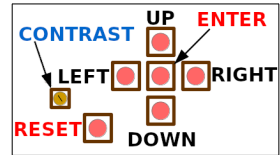

If an update was found the board automatically downloads and installs it. Once the update is finished, the board will restart.

If no update was found, press the “Reset” button to exit the service mode

Loading Change

The Jamex vend device will self replenish change during normal use. However you should first load some change using one of the methods listed in this manual before putting the vend station in service. This allows the vend station to reliably return change and to insure the acceptance of bills. The method used depends on the type of changer. The recommended minimum amounts of change for two of the standard changers are listed as well as the maximum amounts to completely fill them. Because some changers use optical sensors, the max amounts listed can vary a bit between changers of the same model.

Standard three tube changer min and max coin quantities

Nickels	(14 min) = (\$0.70)	(78 max) = (\$03.90)
Dimes	(13 min) = (\$1.30)	(113 max) = (\$11.30)
Quarters	(12 min) = (\$3.00)	(77 max) = (\$19.25)
Tube Meter	= (\$5.00)	Tube Meter = (\$34.45)

Standard five tube changer min and max coin quantities

Nickels	(14 min) = (\$0.70)	(64 max) = (\$3.20)
Dimes	(13 min) = (\$1.30)	(97 max) = (\$9.70)
Quarters	(12 min) = (\$3.00)	(71 max) = (\$17.75)
Dollars	(0 min) = (\$0.00)	(63 max) = (\$63.00)
Tube Meter	= (\$5.00)	Tube Meter = (\$97.65)

Note: Changers vary on the maximum amount of coins per tube. The total amount stored varies based on the tube configuration in the changer. Not all changers store/auto replenish coins in every tube (see page 13).

Load Change Mode:

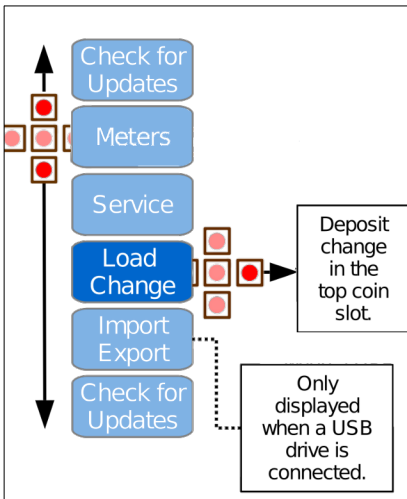

- Press and hold the “Enter” button for 5 seconds to enter service modes.
- Press the “Down” button twice to display “Load Change”.
- Press the “Right” button to enter the “Load Change” mode.
- Deposit coins matching your changer’s configuration in any order through the top coin slot of the Jamex vend station.

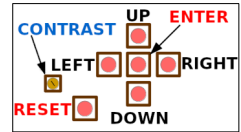

- The tube total and coin quantity are displayed as each coin is inserted.
- Once a tube is full a “Tube full” message is displayed and coins are routed to the cash box.
- When finished, press the coin return on top of the vend station.

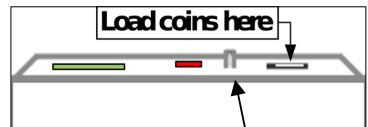

Directly Loading Change Tubes (removable coin cassette)

The next few pages show the steps to use a removable coin cassette. This method is only used for changers with this type of coin cassette.

Setting The Tube Reset Count

The “Reset Count” option is used to program a preset quantity of coins you’ll load in each tube after performing a “Reset Tube” operation.

- Press and hold “Enter” for 5 seconds to enter service mode.
- Using the service mode navigation steps from pages 7 and 8, follow the chart to navigate to the changer “Reset Count” sub menu.

- Set the desired number of coins for each tube. Once set, the value will not reset to zero on its own. If you do not have a removable coin cassette, leave these values at zero.

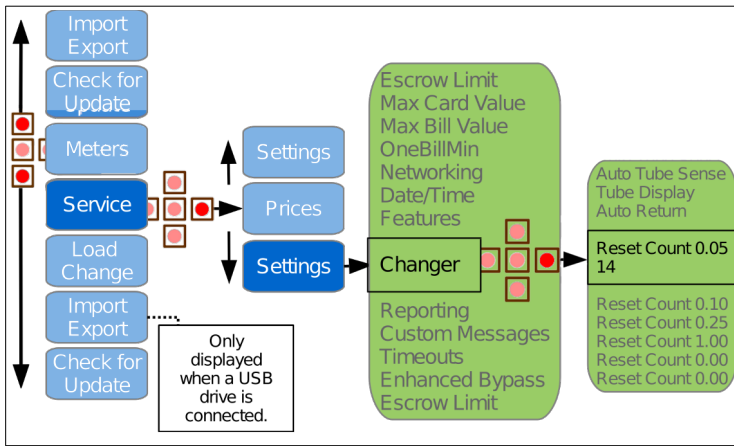

Note: The type of “Reset Count” options shown are based on the changer’s tube configuration. Some changers do not auto store to all tubes. Some redundant tubes will need to be left empty (see page 13). Any auto storing redundant tubes will be grouped as one in the reset count. Load those tubes in an alternating fashion.

Reset Tube Meters:

- Empty the coins stored in the changer's coin cassette.
- Navigate to “Reset tube” service mode option.

- Press and hold the “Enter” button for 5 seconds to set the coin quantity reported in each tube to the “Reset Counts” programmed.

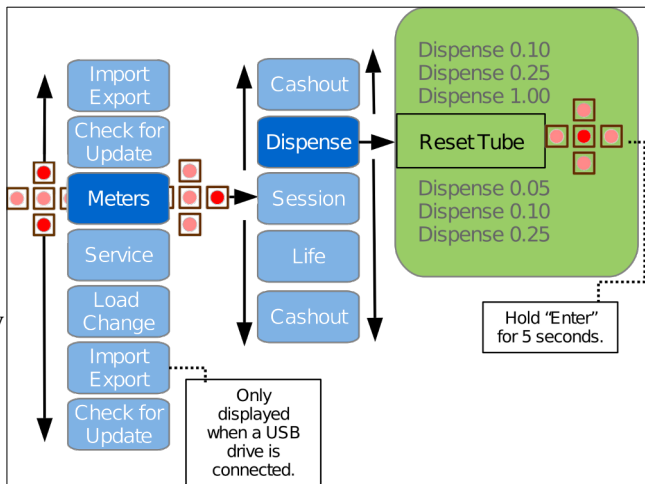

- Load coins directly into the removable coin cassette with the same quantities you programmed in the “Tube Reset Count” procedure.

- Load coins only in tubes that are auto storing. When loading redundant tubes that are auto storing (self replenishing) split coins evenly.

Note: The only time you would not use the vend station's top coin slot to load coins is when loading a removable coin cassette and using the tube reset option to program each tube's value.

- Re-insert the changer's coin cassette and the "Tube" total will now reflect the "Reset Count" coin quantities.
- When using this method to load change you'll want to be sure the "Auto Tube Sense" option is disabled.

How Some Changers Handle Redundant Tubes:

Not all changers auto store coins in redundant tubes. In this example tubes C and E are both quarter tubes. Tube E may remain empty because the changer does not auto replenish change to that tube. If tube A were also a quarter tube, Tubes A, C, and E would be redundant. If tubes A and E are not auto storing, the changer will always leave those tubes empty. You should not load coins into tubes that are not auto replenishing/auto storing.

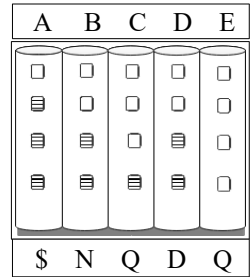

Dead Tube Inventory

Most high capacity changers use a "Dead Tube Inventory". This means that a few coins in each tube will not be paid out. These changers try to pay out coins at a higher speed and having a little extra weight in the tube improves reliability during pay out. These coins are hidden from the vend station and are not paid out. This varies from changer to changer and by coin type.

Auto Tube Sense: This option (page 38) that can be used with some high capacity changers. Enabling this option lets you load change into the coin cassette and press reset. The tube meter will be set to the value the changer reports for each tube. The caveat is even with compatible changers, this method is not 100% accurate. It's varies because of the different methods manufacturers use to calculate this value. A changer's value can be off (high or low) by a few coins in each tube. Some changers do not detect coin quantities at all. They only track when a tube is full or empty. To test this, count out the coins and load them into the coin cassette. Be sure the tube meter is at zero and Auto Tube Sense is on. Press reset (May require a power cycle). Navigate to the dispense modes as shown o page 18. If the changer did not accurately track the coins for each tube, Disable Auto Tube Sense and use the other methods to load change.

Jamex Automated Reporting Software (Optional)

The Jamex Automated Reporting Software enables the Jamex 9550 Series Vend Station to send session and life meter counts, cash totals and event reports to the in boxes of a programmable list of recipients.

Life Meters	Value	Cash Meters	Value
Copy Cash Small BW	5028	Cash	100.60
Copy Cash Medium BW	259	Bypass	19.00
Copy Cash Large BW	106	Bill	80
Copy Cash Small Color	809	Box	20.60
Copy Cash Medium Color	478	Tube	34.45
Copy Cash Large Color	60	Card Add	0.00
Scan Cash Small BW	0	Card Sale	200
Scan Cash Medium BW	0	Host Cash	0
Scan Cash Large BW	0	Host Bypass	0
Scan Cash Small Color	0	Host Card Add	0
Scan Cash Medium Color	0	Host Card Sale	19.00
Scan Cash Large Color	0	Unapplied	0
Print Cash Small BW	188		
Print Cash Medium BW	0		
Print Cash Large BW	0		
Print Cash Small Color	59		
Print Cash Medium Color	0		
Print Cash Large Color	6		

From: Jamex 9557
 Subject: Jamex Event
 To: You
 Report Date: 1/1/2020
 MAC: 00:00:00:00:00

Board S/N Z12345678
 9500 Firmware: 1.7.3

Bypass used for \$9.00 on 1/1/2020 9:00:00 PM

Device is low on change

Denomination	Count
0.05	0
0.10	10
0.25	8
1.00	4
Tube Total	7.00

The software is installed on the vend station and provides reporting of meters and events to facility managers. This information can be used for predictive maintenance and cash collection. A detailed CSV file attachment provides a record that can be imported into a spreadsheet. This is helpful if your site does not allow the use of USB drives for exporting the meters. The Jamex Automated Reporting Software can be programmed to report for the following system event notifications:

- **Power On:** Alerts you to system resets, possible electrical issues or patron tampering.
- **System Updates:** Allows you to keep a record of when the vend station's firmware was last updated and to what version.
- **Bypass Key Usage:** Tracks when the bypass mode is used and the value of that job.
- **Errors:** Some peripheral devices can report errors. A report is sent when an error is reported to the vend station's main board.
- **A Reset at Cashout:** Sends a report of the meter readings and cash total meter values as they were just prior to reset.

- **No Change:** A report of the tube inventory when the “No Change” light comes on. This allows staff to know in advance what type of change needs to be loaded into the vend station.
- **Number of Bills:** Lets you know when a programmed number of bills have been stacked in the bill box. Set this to just under 300 or 500 based on the bill acceptor's maximum bill storage.

Jamex Automated Reporting Software Requirements

Aside from purchasing the Jamex Automated Reporting Software to be installed on your vend station's board, you will also need an email account from which the vend station can send reports from. You can use the free Jamex email server or choose to use your own SMTP email server. Your IT will need to be sure the email server's port is open in the firewall for the Jamex Vend Station.

Jamex Free Email Server

Jamex provides free use of an email server. Use of the Jamex email server is a safe and simple implementation since it is dedicated to only sending emails generated by your Jamex device. You'll simply need to program the list of "To" addresses, set a machine name and be sure port 465 on your network allows inbound and outbound traffic from the vend station to the internet. See pages 39 and 40 for all the reporting settings.

Customer Selected Email Server:

You can use your own email server but you will be responsible for it's configuration. Some email accounts require different security settings to be able to send emails from an automated device and some services may block emails sent from this type of device all together. This refers to a device that can only connect to the server with a user name and password. It's not like a cell phone or tablet so it can not respond to security prompts or dual authentication. These newer security requirements have led email providers to treat devices like these as less secure. They are sometimes referred to as LSAs (less secure apps).

When using the optional reporting feature please consider allowing Jamex access to your emailed reports by selecting "Yes" to the "Share data with Jamex" option in the service modes. This information is used to help us improve our products and services.

- No credit card data is ever saved or shared with Jamex,
- Your data is not sold in anyway.
- Your email address will not be shared with any third party or added to any mailing lists.
- If you allow sharing of your data, you can easily request a copy of a specific report by emailing support@jamexvending.com.

Importing Email Settings

You can edit an exported config file or use the Jamex 9550 Web Tool and import a configuration file (page 6) to program your email server's settings. Enter all the information provided to you by your IT staff. If you use the Jamex free email server, you'll only need to choose the desired reports, a from name and the list of "To" addresses. The information shown below is for display purposes only.

Reporting	
Reports Enabled:	Yes ▾
Server URL:	smtp.my.com
Server Port:	587
Server User:	Jamex9557
Server Password:	password 0
From Address:	myaccount
From Name:	Jamex room 1
To Addresses:	myemail@my.com
Date (Day of month):	10
Day (Day of week):	Not set ▾
Hour (Hour of day):	8
Report Power On:	No ▾
Report Updates:	Yes ▾
Report Bypass:	No ▾
Report Peripheral Error:	Yes ▾
Report Cahsout:	Yes ▾
Report No Change:	No ▾
Report # Bills:	285

Note: If you are using the Jamex mail server and accidentally import a config file that overwrites the settings, Enter service modes and set Jamex mail to "Off". Save and exit the service modes. Enter the service modes again and set it to "On" to restore the email server settings. Export a file with the new settings to avoid this from happening in the future.

Cashing Out the Vend Station

Removing Cash Cash Drawer or Cash Box

- Unlock the Cash Box.
- Pull the drawer straight outward toward you.
- Use caution as a full cash box can be very heavy.
- When replacing the cash drawer be sure it is in place correctly.
- Lock the cash box to prevent it from shifting and causing coin jams.

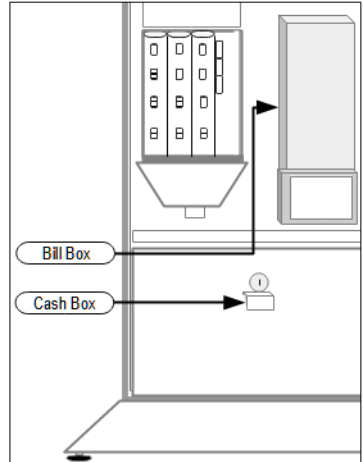

CoinCo Bill Acceptor

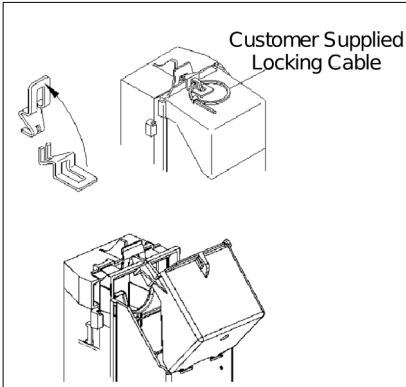

- Unlock and remove any customer supplied lock or locking cable.
- Remove the optional silver colored locking bracket on top of the bill box by lifting up on the front of the bracket so that it rotates up and releases the forked end.
- Pull the top of the bill box lid toward you to open to remove bills.
- Close the lid and then reinstall any locking bracket or cables.

Apex 7000 Bill Acceptor

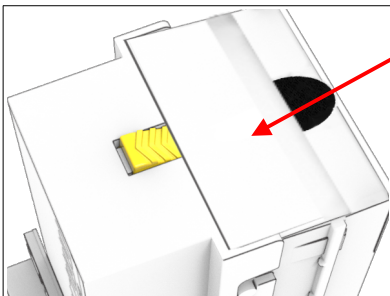

Lift the top door of the bill box away from you to retrieve the bills.

Removing Change From the Change Tubes

It is recommended to leave the change in the tubes and factor in the difference in tube meters as part of the reconciliation process (See pages 20 – 22). You will also see on those pages that there are a few different options regarding using the same tube meter each time.

Lowering The Tube Meter (Dispensing Coins)

- Press and hold the “Enter” button for 5 seconds to enter service modes.
- Select “Meters” by pressing the “Right” button.

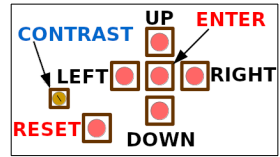

- Use the “Down” button to navigate to “Dispense”.

- Select “Dispense” by pressing the “Right” button.

- Use the “Up” or “Down” buttons to select a denomination.

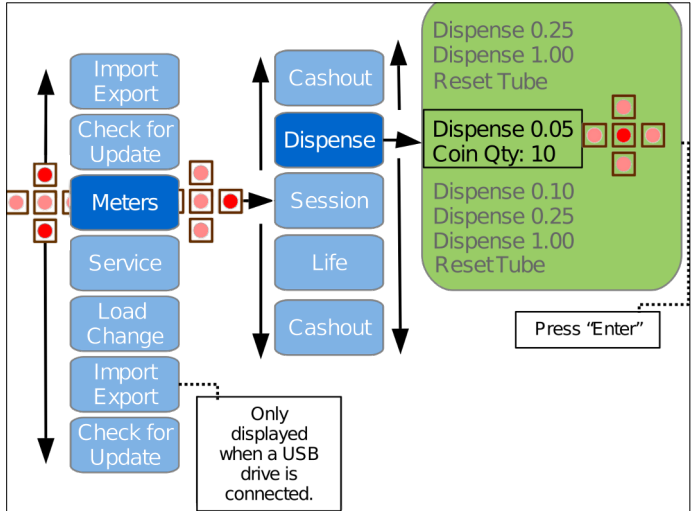

- Press “Enter” to pay out a coin while the coin denomination and "Coin Qty" are displayed. The number of coins quantity is reduced by 1 each time the changer's payout mechanism activates to pay out a coin.

- Hold “Enter” to pay out multiple coins.

Note: A jam in the payout section results in the changer going through the motions of paying out coins and lowering the tube's meter each time but because coins were stuck, none were returned. Once the jam is corrected, You'll need to continue paying until the tube is empty even though the tube meter is at zero. If the coin cassette is already empty, Press up or down until "Tube Reset" is displayed. Press and hold enter for 5 seconds. This will reset all the tube meters to zero however his will not work if you've programmed something other than the default of zero in the settings mode described on pages 10 and 11.

Never turn a vend station upside down to empty change!

Retrieving The Cash Meters

There are three ways to get the Cash Out meters.

1. Manually scroll through each meter and note it in a log.

Reviewing the "Cashout" Meters in the Service Modes

- Press and hold the "Enter" button for 5 seconds to enter service modes.
- Enter "Meters" menu by pressing the "Right" button.
- Use the "Down" button to navigate to the "Cashout" selection
- Select "Cashout" by pressing the "Right" button.
- Use the "Up" or "Down" buttons to review all of the "Cashout" meters. Each meter's name will be on the top line with the value on the bottom line.

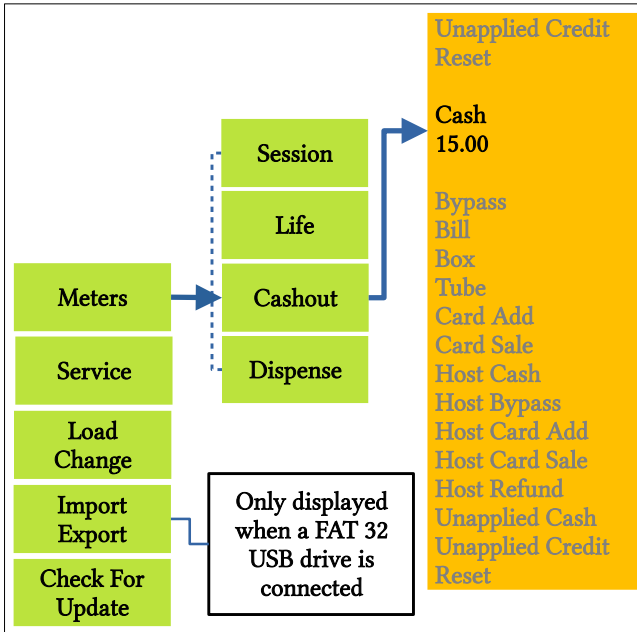
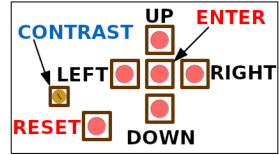

The "Cashout" meters, with the exception of the "Tube" meter, can be reset following a reconciliation. See page 26. The "Tube" meter is reset by paying out coins through the "Dispense" mode (page 18) or the "Tube Reset" operation (pages 10 — 12).

2. Exporting the Meters to a USB Drive.

Note: This needs to be done before meters are reset.

USB-CSV Meter Export

Use the USB-CSV export function to export the meter readings to a CSV (comma separated values) file that can easily be imported into a spreadsheet.

- Insert a FAT 32 formatted USB drive.
- Press and hold the “Enter” button for 5 seconds to enter the service modes.

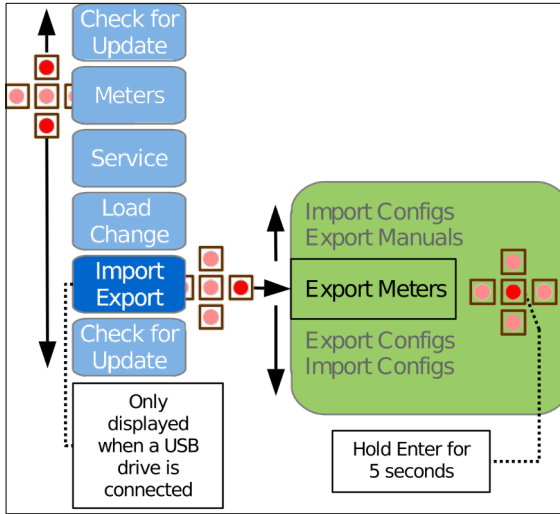
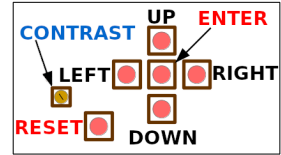

- Use the “Down” button to navigate to “Import/Export”.
- Use the “Right” button to navigate to “Export Meters”.
- Press the Hold the “Enter” button for 5 seconds to complete the desired function.
- Once complete, the vend station will exit the service modes.
- Remove the USB drive and connect it to a PC to view the file.
- Open a spreadsheet program and import the CSV (Comma separated values) meters file.

Note: The file name will show the date and time it was exported.

Example: jamex_meters[02-06-18 03.42 pm].csv

3. Use the optional Jamex Automated Reporting Software

The Reporting Software is covered on pages 14 – 15. The meters report is emailed to you when the cash/session meters are reset (page 26).

Reconcile the Cash Meter Totals With the Cash On Hand

Cash Totals

Different features/options of your Jamex 9550 Series Vend Station can give you more than one “Cash” meter to consider. These would be added together to calculate the total cash taken in for this period. See page 24 for detailed meter descriptions.

Cash: This meter is incremented by the amount deducted from cash deposited into the vend station for copier vended functions.

Card Add: N/A

Host Cash: Similar to the cash meter but reflects charges made by vending software running on a connected host PC. This meter is an aggregate total the Host PC charges.

Unapplied Cash: This meter is used to track funds that could not be tracked to any other meter. The conditions listed below will increment this meter.

- Patrons may get short changed if using the vend station while the no change light is on.
- A copier may send a charge signal after the vend station has disabled it resulting in a partial charge.
- The vend station can be programmed to return or keep any unused funds if the device is left idle. Funds kept are tracked here.

Unapplied Credit: This meter is used to track funds that were deducted as part of the minimum credit transaction setting. See page 9 for details.

Cash on Hand

When reconciling, most customers only remove the funds from the bill box and bottom cash box. We refer to those funds as "Cash on hand". The corresponding cash meters are the "**Bill**" and "**Box**" meters. Cash on hand should be equal to the sum of those two meters. You may expect the cash on hand total to be equal to the cash meters but this is not always true. It doesn't mean you're short funds or you've collected more than you should have. It varies because of the way coins in the change tubes are paid out and replenished. You can account for this by keeping a record of the previous and current tube total meters and noting the difference. The next section explains how the tube difference comes into play when reconciling and goes over how to factor in the tube meter difference when you reconcile cash on hand against the cash meters total.

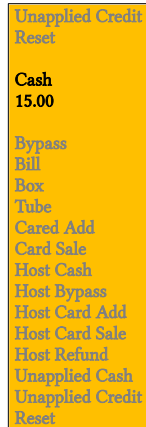

Unapplied Credit
Reset
Cash
15.00
Bypass
Bill
Box
Tube
Cared Add
Card Sale
Host Cash
Host Bypass
Host Card Add
Host Card Sale
Host Refund
Unapplied Cash
Unapplied Credit
Reset

Negative Tube Difference

If there is a negative difference in the tube meter when compared to the tube meter from the previous reconciliation period, it means larger bills were used to pay for small copy jobs. This used the existing change in the change tubes as it was returned to the patrons in exchange for bills. These bills are now part of your “cash on hand”. The funds removed from the bill box and cash box will be greater than the cash meters. This amount will be equal to the negative tube difference.

Negative Tube Difference Adjustments

Your cash meters totaled \$45.00 but you've removed \$50.00 in bills and coins. The extra \$5.00 of that cash on hand came from the change tubes. The formula would be

Previous Tube Meter = 20.00

Current Tube Meter = 15.00

$$\begin{array}{r r r r r r} \text{cash on hand} & + & \text{negative tube difference} & = & \text{cash meter total} \\ 50.00 & + & (-5.00) & = & 45.00. \end{array}$$

Positive Tube Difference

If there is a positive difference in the tube meter when compared to the tube meter from the previous reconciliation period, it means coins went into the change tubes to replenish depleted change. These coins did not go into the cash box at the bottom and are not part of your cash on hand. Cash on hand will be lower than the cash meters by that amount.

Positive Tube Difference Adjustments

Your cash meters totaled \$45.00 but you've removed only \$40.00 from the vend station. It's because \$5.00 of the funds taken in went into the change tubes. The formula would be

Previous Tube Meter = 20.00

Current Tube Meter = 25.00

$$\begin{array}{r r r r r r} \text{cash on hand} & + & \text{positive tube difference} & = & \text{cash meter total} \\ 40.00 & + & (5.00) & = & 45.00. \end{array}$$

Note: Sample spreadsheets are available upon request by emailing info@jamexvending.com

Alternative Method Using a Predetermined Tube Meter

You may choose to eliminate the need to reconcile cash on hand against a fluctuating tube meter. Choose a starting amount of coins for each tube that you want to begin each reconciliation period with. This will give you the same starting tube meter each time. The next two sections describe the steps to set this up but it will vary base on the type of coin changer in your vend station.

Changer With a Removable Coin Cassette

You can use the “Tube Reset” procedure (page 11) for changers that have a removable coin cassette. This does add a few extra steps to your cash out process.

- Combine coins from the changer’s coin cassette with the coins in the cash box making them part of your “Cash on Hand” funds.
- Use those coins to reload the coin cassette. Drop these coins directly into the coin cassette to exactly match the “Reset” values programmed (pages 10 — 13).
- If you are short a specific coin denomination, change out bills from the bill box to reach the desired reset values for each tube. Do not use any of the coins in the cash box to make change for the bills. When you use bills to make change, be sure to note the transaction in your logs as the total of bills removed is now lower than the “Bill” meter but your overall “Cash” meter will match your “cash on hand” total.
- Load the coin cassette back into the changer.
- Perform a “Reset Tube” operation (pages 11 – 12) to reset the tube meter to the programmed “Reset Count” you've chosen. This will set the tube meter to match the reset count and that should match the amount of coins you've just loaded into the coin cassette.

Hint: Mark each coin cassette’s tubes once the desired amount of coins are inserted. After that you may not need to count out coins each week. You would simply add or remove coins to align them with the mark you placed on each tube.

Changer With Non Removable Change Tubes

You can use a desired starting tube meter with a changer that has stationary tubes. You'll need to manually pay out change (page 18) from each tube to adjust the coin's meter lower. If you need to add change you would use the coins from the cash box to load change (page 10) to reach each tube's target value.

Attention: Manually paying out and reloading change to reach a desired tube value will put a lot of extra wear and tear on the changer and add extra time to your reconciliation process. If you choose to adjust your tube meter in this way, you may experience premature hardware failure.

Visit the support section at jamexvending.com to review all the available videos regarding your Jamex 9550 vend station.

Detailed Meter Descriptions

Session Meters

These meters track the count of all vended functions (copies, prints, scans, faxes). They are reset at the same time the vend station is cashed out to make it easier to separate counts from each reconciliation period.

Life Meters

These meters track the same information as the session meters but these counts are not re-settable. These meters show how much use the vend station gets. Heavily used vend stations will require more maintenance.

Cash Meters

- **Cash** is the total cash charged for copier vended functions.
- **Bypass** is the total value of vended copier functions using bypass.
- **Bill** is the total of bills stacked in the bill acceptor.
- **Box** is the total value of coins routed to the cash box in the bottom.
- **Tube** is the total of change currently in the change tubes.

Optional Cash and Card Meters depending on configuration

- **Card Add** N/A
- **Card Sale** is the total value deducted from credit cards.
- **Host Cash-** Host cash is the total cash charged by software running on a connected PC.
- **Host Bypass-** is the total value of bypass operations performed by software running on a connected PC.
- **Host Card Add-** N/A
- **Host Card Sale-** is the total value of funds charged to credit cards by software running on a connected PC.

Unapplied Cash is the total of funds that were received but could not be tracked to a specific meter.

Unapplied Credit is the amount left over when a copy job is done for less than the minimum transaction amount. For example: If your card copy price is 10 cents and your minimum transaction amount is 25 cents, and a patron makes a single copy, the card cash meter went up by 10 cents but the credit card was charged the minimum 25 cents. This meter tracks the 15 cents that was left after the transaction ended.

Reading the Meters:

The meters can be viewed through the service modes using the six button array on the vend station's board as well as being exported as a CSV (comma separated values) file to a USB drive for review on a computer. If your system has been purchased with the Jamex Automated Reporting Software, these reports can be e-mailed to a programmed list of email addresses.

Navigating the Service Modes:

“Right” button moves into the service menu.

“Left” button returns to the previous menu.

“Up” and “Down” buttons move between selections in a mode.

“Enter” selects a mode, performs an action or saves a setting.

“Reset” exits service modes. (a changed setting must be saved first).

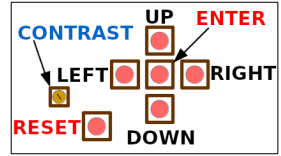

- Push and hold the “Enter button for 5 seconds to enter the service modes. “Meters” will show on the top line of the display.

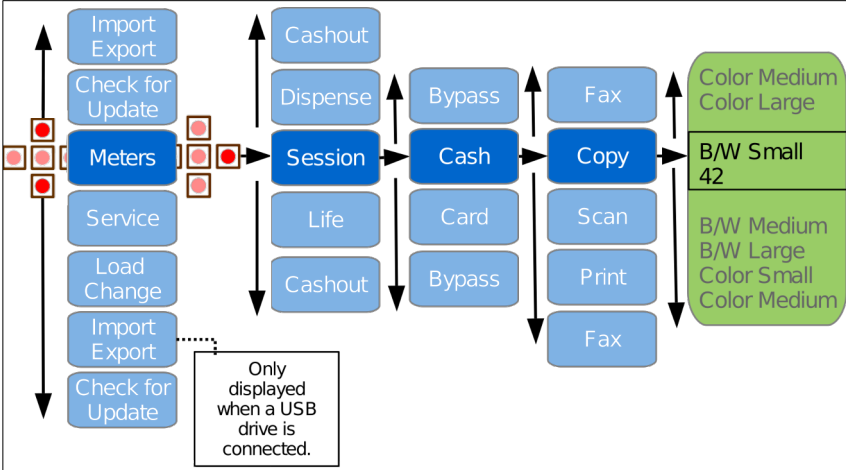

- Press the “Right” button to enter the “Meters” menu. “Session” will be displayed.
- Press the “Right” button again to enter the “Session” menu and “Cash” will be displayed.
- Use the “Up” or “Down” buttons to choose the payment type to review “Cash”, “Card” or “Bypass”.
- Press the “Right” button to enter the selected feature charged by that payment type.
- The feature “Copy” will be displayed. Use the “Up” or “Down” buttons to review “Copy”, “Print”, “Scan” or “Fax” meters.
- Press the “Right” button to view the selected meters.
Note: Your copier may not support vending of all the functions shown here and therefore those meters would not be displayed or left at zero.
- “B/W Small” will be displayed on the top line and a number on the bottom line. This is the number of copies of this type made since the last reset.

B/W Small
42

- The “Up” or “Down” buttons allow you to review the meters of all other copy types recorded.

Reset Session and Cashout Meters

- Press and hold the “Enter” button for 5 seconds to enter service modes.
- Select “Meters” by pressing the “Right” button.
- Use the “Down” button to navigate to the “Cashout” selection.
- Use the “Right” button to select “Cashout”.
- Use the “Down” button to navigate to “Reset Cash/Session”.

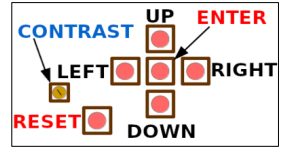
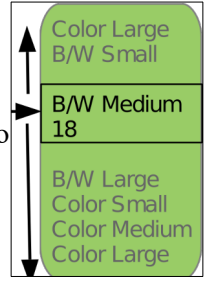

- To reset these meters to zero use the "Up or Down" buttons until the “Reset Cash/Session” option is displayed.

Reminder: If you use the report export feature (page 20) Be sure this has been done before resetting the Cash/Session totals. If you are using the optional Reporting Software you can move on to the next step

- Hold the “Enter” button for 5 seconds to reset all Cash (tube meter excluded) and Session Meters to zero.

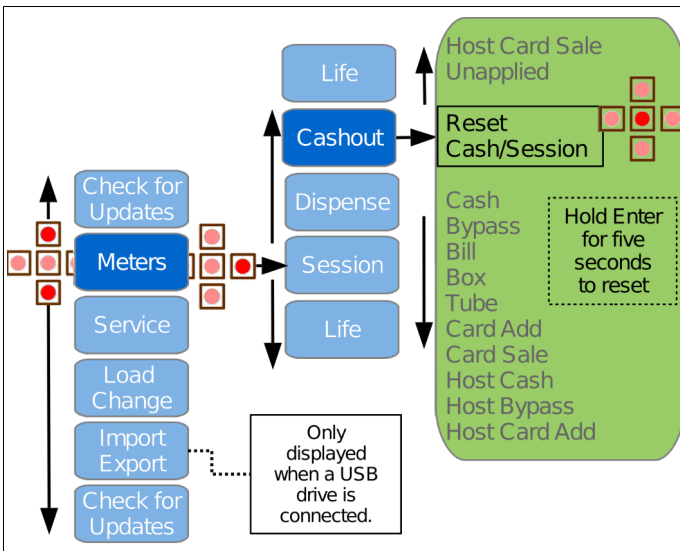

- If the Jamex Automated Reporting Software was installed, a report was automatically sent to the programmed email addresses containing the meter values as they were just prior to performing the reset operation. A CSV file is attached containing the same information.

MAINTENANCE AND TROUBLESHOOTING

Your Jamex Vending System requires occasional cleaning of the bill acceptor, coin changer, and card reader. The frequency of cleaning depends on the environment and amount of use. Debris can be dropped into the coin slot by patrons and cause coin jams. Instructions for clearing jams are listed here. For your convenience, instructional videos are also available in the “Support” section at jamexvending.com

Check for a firmware updates:

You should occasionally check for firmware updates (page 10).

Always disconnect power before performing any maintenance

Cleaning the CoinCo BP4-BX5 Bill Acceptor

- Remove any locking plates or cables from the top of the bill box (page 17).
- Push the bill box tab away and slide the bill box upward and off.
- Push up on the locking tab on the bottom and pull the lower housing towards you.
- Clean plastic parts and belts with a mild soap and water solution and a soft cloth. Only use Isopropyl alcohol to clean the metallic magnetic read head located in the in the main frame of the bill acceptor.

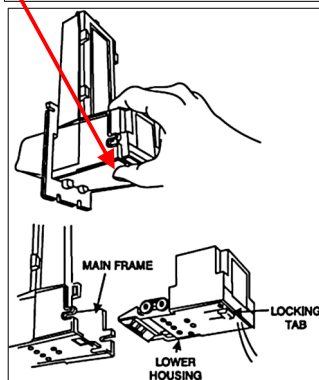
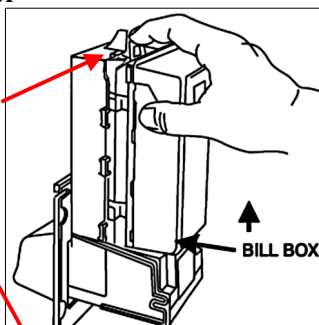

Bill Acceptor Issues:

If the bill acceptor runs continually, it maybe a bill jam or a stuck anti-cheat lever.

- Disconnect the power to the vend station.
- Remove the lower housing of the bill acceptor.
- Remove any pieces of a bill you may find and verify the anti-cheat lever on the lower housing moves freely. The fingers of the lever should return to a forward resting position as shown.
- If the anti-cheat lever is out of position and not moving freely, lock it back into position by pulling the fingers straight upward until a "click" is heard.
- Once the levers move freely, insert the housing and connect the power.

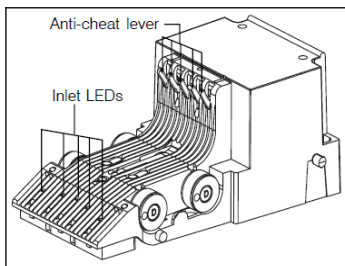

There is a slight pause before a bill is rejected. Watch the display just before the bill is returned for a message of "**LoChange**", "**Too Much**" or "**Denomination Too Large**. If there seems to be enough change, you may need to empty and reload the change (pages 10, 13, 18). If the message "Too Much" is displayed, it indicates the value of the bill would credit an amount higher than the "Escrow Limit" setting and The "Max Bill" setting limit the denominations allowed. See page 36.

If a bill is rejected quickly or is not pulled in all the way, it is possible the bill acceptor's sensors have failed and it needs to be replaced. First review the video on how to clean a bill acceptor in the support section at jamexvending.com If this only happens with **5 dollar** bills, older bill acceptors may not be programmed to accept the latest 5 dollar bill. Most vend stations use a CoinCo BP4-BX5. Look at its serial number tag to see if a \$5 symbol is there, if not there, contact Jamex for a replacement.

The Bill Acceptor Appears To Be Dead.

The CoinCo bill acceptors found in almost all Jamex vend stations have a flash code LED that could indicate a problem. The BP4 model can indicate three possible issues.

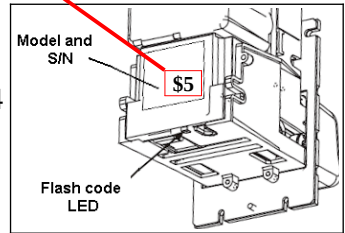

1. The light seems to **blink on and off steadily** (Check the bill box). Empty the bill box (page 17). Remove/check the bill box (page 27)
2. The light **blinks twice**, there is a slight pause and then it repeats the sequence (Stuck bill). Bill jam or stuck anti cheat levers (page 27).
3. The light **blinks three times**, there is a slight pause and then it repeats the sequence (Return for Service). Contact Jamex for a replacement.

Cleaning the Apex 7400

- Push the top yellow lever forward.
- Hold the lever forward and lift the bill box up slightly.
- Pull the bill box towards you.

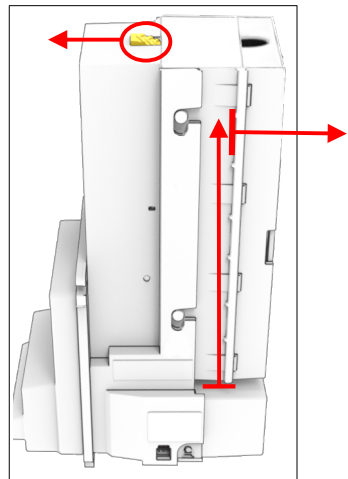

- Press up on the release tab at the bottom of the bill acceptor.
- While holding the release, Pull the Lower Transport towards you.
- Use a lint free cloth lightly moistened with water to remove dust from rollers and optic sensors.
- Use the cloth to clean away any dust from inside the bill acceptor.

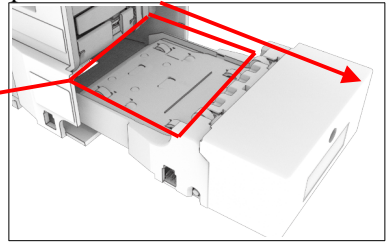
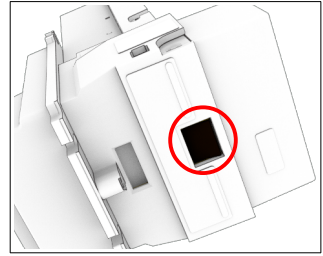

Apex 7000 Error Codes

The codes are displayed by flashing the lights on the front bezel. There is a three second pause before the code is flashed again.

- The front bezel **flashes once**, Remove Lower Transport and remove debris or stuck bill.
- The front bezel **flashes twice**, Remove the lower Transport and bill box to check for a stuck bill.
- The front bezel **flashes three times**, Empty the bill box.
- The front bezel **flashes four times**, The bill box has been removed. Be sure it is installed and properly seated.
- The front bezel **flashes five times**, Return the bill acceptor for service. Contact Jamex for a replacement.

If the front bezel is **flashing rapidly** it indicates an attempt to cheat the system with possibly something attached to the bill to pull it back out of the bill acceptor. The sensors that detect a this may also be dirty. Remove the lower transport and clean the sensors. These sensors are located on the sides of the lower transport assembly.

Cleaning the Coin Changer

Coins share a common coin ramp that will need to be cleaned

- Open the vend station and press the coin return lever to move the acceptor gate located above the change tubes.
- Using your fingers, pull the spring loaded acceptor gate open. Do not force the gate to open farther than is natural.
- Wipe the exposed coin ramp and inner surface with a damp cloth.

- With some changer's you will be able to open the changer's coin channel and clean that area as well.

Never submerge any part of the bill acceptor or changer in water or clean with a wire brush, steel wool, scouring pads or solvents. Do not use lubricant on any part of the coin or bill acceptors.

Clearing Coin Jams In a Three Tube Changer

Always disconnect the power first. For your convenience, a detailed video is also available in the support section our web site at jamexvending.com.

For a jam in the coin acceptor upper path area, use the following steps to help dislodge coins:

- Raise the two acceptor latches and tip the top of the acceptor down.
- Unplug the acceptor ribbon cable from the main logic board.
- Partially stand the acceptor up and lift up and forward and pull the bottom outward until the acceptor clears the housing slots.
- Press the top coin return lever of the acceptor.
- Using your fingers, pull the spring loaded acceptor gate open. **Be careful not to pull the gate too far open.**
- Turn the acceptor upside down and tap to remove any stuck coins.
- When reinstalling the acceptor, use caution to avoid bending any pins when reconnecting the ribbon cable.

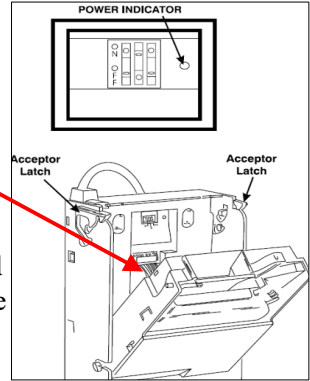

Instructional videos for clearing jams and removing the tubes from a three tube changer can be found in the support section at jamexvending.com

Clearing Coin Jams (Five Tube Changer)

The diagnostic panel on a 5 tube changer may look like this.

Do not press the function buttons unless instructed to by Jamex support.

If the **"DIS"** LED is blinking, it indicates a coin jam in the changer.

- Swing the acceptor gate assembly (the piece that moves when coin return is pressed) away to look for coin jams.
- Push the release lever to the right and swing open the changer's coin channel cover to remove any jams.

Note: The release lever is made of the same clear plastic as the channel assembly so it may be hard to spot at first.

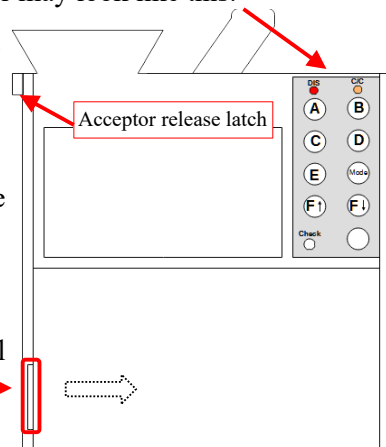

- If you need to remove the acceptor, Power down the vend station first.
- Push up on the acceptor release latch and swing the acceptor down.
- Carefully disconnect the wires from the back of the acceptor and lift it up and out.

The **"C/C"** LED is blinking indicates a jam in the coin/tube cassette.

- Push down on the cassette latch in the top center of the coin cassette.
- Swing the top down toward you and lift up to remove.
- Look for coins in the tube that may be stacked incorrectly.
- If you had to dump the change out of the tubes, It's best to get the tube meter to zero and reload the change as described on pages 10 — 12.
- If both the **"DIS and C/C"** LEDs are flashing, you may need to clean the coin path. To clean this area power down the vend station and use a mild soapy water solution on a damp cloth.
- If the **"Check"** LED is still blinking after you have removed any jams and re inserted the coin cassette. Press the unmarked button beside it to try and clear the error.

Caution: Be careful not to lose or damage the plastic coin slide piece that slides into the bottom of the coin cassette assembly.

Changer Payout Issues

Payout Section Problems (Three Tube Changer)

- Follow the steps in the “Clearing Coin Jams” (page 30) to remove the acceptor.
- Inside the vend station, look at the two coin chutes just to the right of the top of the coin tubes.
- If the jam is not too severe then it may be able to be released from the top of the chute. Use something small to try to move the coins to get them to fall.
- Severe jams will require you to remove the change tubes. An instructional video is available in the support section at jamexvending.com. **Do not turn the vend station upside down!**

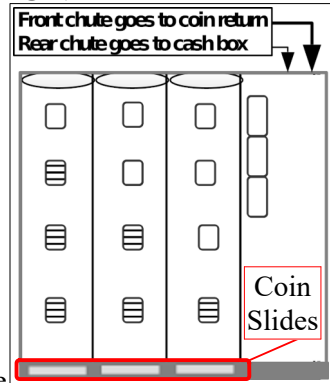

A Deadened Sound During Payout (Three Tube Changer)

When there is a deadened sound when the changer attempts to return change, a coin jam in the payout area is usually the cause. Below each tube is a knock out for the coin slide. The coin slide is a flat plastic piece that has a hole slightly larger than the coin. When it moves forward it aligns with the bottom of the tube and the coin drops into the slide. When the slide returns, the coin is dropped into the coin return cup. Something is stopping the coin from dropping into the coin slide. You may be able to use something like a letter opener to slide in on top of the coin slide to go between the coins pushing the coin into the slide. **DO NOT** twist the letter opener in any way. Push it straight in and pull it back out or you will permanently damage the changer. Do not reload problem coins back into the changer. Once the jam is cleared, payout all the coins in that tube. Continue payout as needed until the coin's tube meter to 0 before entering the load change mode to reload it. Keep in mind patrons did not receive all of their change so there will now be more cash on hand than expected when reconciling. More severe jams require the removal of the change tubes to access the payout area. An instructional video is available in the support section at jamexvending.com.

If there isn't a payout sound but the tube is full it is likely because the meter for the tube storing that denomination of that coin is at 0.00. This can be the result of a payout jam that ran the tube's meter to zero but never actually paid out any coins or by improperly loading change. You'll need to fully empty that change tube and reload the coins properly (page 10). Check the other tubes to verify they have been loaded correctly.

There is a normal pay out sound but coins are not being returned.

The tube may be empty but the tube meter for that coin still shows coins in the tube. The tube meter and tube inventory need to match. Zero that tube (page 18) and reload the coins properly (page 10).

For the three tube changer, inspect the coin slides as discussed on the previous page.

If this is the Conlux MCM5 changer (clear removable coin cassette), the white plastic coin slide may have fallen out of the coin cassette. Since it's not obvious where it came from, sometimes it will get placed directly inside the changer at the bottom. If you see the coin slide inside the changer, remove it.

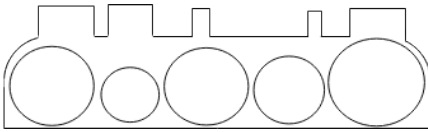

Coin Slide

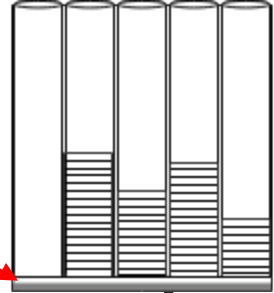

Insert the coin slide into the back of the coin cassette into the slot at the bottom. It is inserted between the coin cassette's coin tubes and the gray plastic piece. The flat side of the coin slide is the top. It can only be inserted one way.

Tube Meter Jumping Up After a Reset

This could be caused by the "Auto Tube Sense" setting. Your changer may need this turned off (page 38).

The tubes of a three tube changer may not be installed properly. Review the video on how to remove a changer's tubes in the support section at jamexvending.com

The "No Change" light is on but there is plenty of change.

The change was loaded improperly. Empty the changer (page 18) and reload the coins properly (page 10)

Clearing A Jam In The Cash Box Chute

Remove the coin acceptor as described on page 30 and remove the cash box as described on page 17. Look to the rear of the housing where the cash box was inserted. You may see coins jammed in the chute's exit area. Pull a few coins out of the exit area and the rest usually fall. Drop a coin directly in the cash box chute pictured on the previous page to be sure it is clear. When reinserting the cash box, be sure it is pushed back in place and locked to prevent it from shifting causing coins to catch on the edge of the cash box and jamming.

Replacing Paper in Optional Receipt Printer

The receipt printer uses 2.25" wide thermal paper Jamex P/N 202377.

1. Disconnect the power to the vend station.

2. Unscrew the two thumb screws underneath the back end of the printer shelf to release the printer. The screws will not fall out.

3. Slide the printer back from the opening in the housing.

4. Looking directly at the front of the receipt printer. There is a metal tab on the upper left corner. Push the tab away until the print head guide is released as shown.

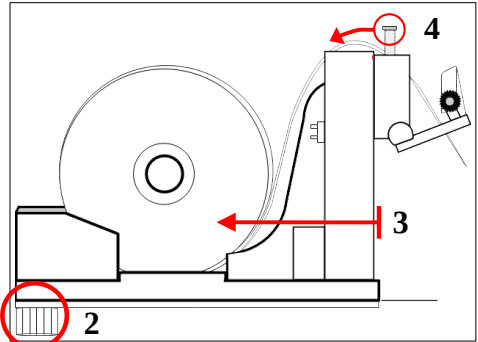

- Feed the paper over the top and through the guide as shown being sure the paper is feeding from the bottom of the roll.
 - Leave enough length to also pass the paper through the exit slot in the housing when reinstalling the printer.
5. Swing the print head guide up and be sure it locks back into place.
6. Slide the printer forward on the receipt printer shelf and feed the paper from the guide out of the housing's exit slot.
7. Tighten the two thumb screws underneath the back of the printer shelf.
8. Reconnect power.

PC Communication Issues

Vending Software Not Seeing Correct Credit

A vend station will not report the wrong value to software. Software showing an odd value is usually a software or PC configuration problem.

PC Configuration for USB Connection

Jamex USB devices require a driver to function. Look in Windows Device Manager under "Ports (COM and LPT) and verify there is a Jamex USB Serial Port with a COM number. The driver can be found at www.jamexvending.com/downloads/drivers

Note: Jamex equipment manufactured with a USB port prior to April of 2014 will use the legacy driver. These drivers are the same versions but look for different hardware. The Legacy driver will simply show as a USB serial port. Newer Jamex boards show as a Jamex USB Serial Port.

Vending Software Configuration

Vending software often requires you to input the type of vending device and the COM port the device is on. Consult the software vendor about configuring these settings. Many vendors do not yet have the 9557 model listed. Use 6557 model instead. Review the PC Configuration section above to verify the COM port number.

Hint: Windows assigns a new COM port number for a new board. If a board is replaced, Uninstall the old Jamex device before disconnecting it. Windows should then reassign that same port number to the new board.

USB Cable

- Verify the USB connection from the JPC USB port (page 46) to the USB port on the PC.
- Inspect the USB cable for damage or simply replace it to test.

Verify The Firmware Is Compatible With A PC

For a Jamex Vend Station to communicate with a PC, specific Jamex firmware is required. Use the first few steps listed in the using the Web Tool to get your firmware version (page 5). Look for the lettering "JPC". If you do not see it, the USB port on the board will not talk to a PC. Contact Jamex to purchase a firmware reconfiguration service. A network connection is required. Connect the vend station to your network (page 4). This can only be done through a network connection.

Copier Errors

Some copiers need to be in constant communication with the vend station. If the vend station is powered off or its reset button is pressed while prices are displayed, a copier can display an error. Restart the copier but be sure the vend station is fully booted first. Be sure to power off the copier before pressing the reset button while out of service modes, unplugging the vend station or updating the firmware.

Power Problems

If the power supply LED is not lit, Verify the wall outlet is working and the connection from the wall outlet to the power supply is good. There could be a short in the vend station. To test, unplug the power supply from the wall and then disconnect the power connection in the base of the vend station. Wait a few minutes and reconnect the power to the wall but do not connect the vend station. If the power supply LED now lights, there is likely a short in the vend station that caused the power supply's protection circuit to kick in. A common cause of shorts are loose coins in a vend station that has been tipped over. Now coins from inside the change tubes have ended up on or behind the main board.

If the power supply LED is lit

You'll need to check the power connection in the base. It may be damaged in such a way that even though it looks connected, the sockets and pins inside the connector are not making contact.

- Disconnect the power from the wall and disconnect the cable under the base and look in the end that goes toward the vend station (sockets)
- Hold the black end of this connector while pushing the gray cable into the connector. Push the sockets as far forward as they can until they lock in place. If they do not lock in place, the cable needs to be replaced.

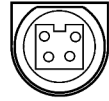

Hint: To restore power while waiting for a replacement cable, Go through the steps above to push the gray cable to move the sockets forward. Now hold the cable in place while connecting the power supply connector. Then reconnect the power to the wall outlet.

Complete List Of Service Mode Settings

Under the service mode settings menu are the following settings and their intended functions and options. See the “Service Mode Layout (Settings)” on page 47 for each setting's location.

	Description and settings	
Escrow Limit	Sets maximum amount of cash that can be inserted into the vend station at one time.	
	Default setting	\$20.00
	Optional settings	\$0.00 - \$80.00
Max Card Value	Sets the maximum value that a stored value card can be revalued up to. A stored value card with an existing value over this setting will not be accepted.	
	Default setting	\$25.00
	Optional settings	\$0.00 - \$599.99
Max Bill Value	Controls the largest denomination bill that can be accepted. This way you can set a higher escrow value to allow for higher cost jobs but set a lower bill value to stop patrons from using large bills to pay for small jobs and depleting the change.	
	Default setting	5.00
	Optional settings	0.00, 5.00, 10.00, 20.00
OneBillMin	Forces a patron to make at least one copy when using a bill. This prevents patrons from using the vend station as a bill changer. 0.	
	Default setting	off
	Optional settings	on, off

Unrestricted Bill Accept	Allows bills over escrow and accepts bills regardless of the amount of available change.	
	Default setting	off
	Optional settings	on, off
FDI Mode	Xerox specific setting for a Foreign Device Interface.	
	Default setting	Color
	Optional settings	Color, B/W, B/W (L)
Interface BR	Kyocera specific setting for copiers to adjust the baud rate.	
	Default setting	Auto
	Optional settings	Auto, 9600, 10000
Pvender Mode	Sharp specific setting used with an alternative vend mode. Note: Pvend3 setting does not allow network printing.	
	Default setting	Pvend1
	Optional settings	Pvend1, Pvend3

Networking	Description and settings	
MAC Address	Displays NIC Card's MAC address. Note: Must be connected to a live network drop or MAC address will not be displayed.	
DHCP	Automatically sets network settings received from your DHCP server. Note: Manual programming of network configuration is done through configuration import from USB. See pages 5 — 6 for details	
	Default setting	on
	Optional settings	on or off
IP Address	Displays the current IP address.	
Gateway	Displays the currently set gateway IP address.	
Netmask	Displays the currently set Subnet Mask	
DNS 1	Displays the currently assigned main DNS server	
DNS 2	Displays the currently assigned secondary DNS server.	
Proxy Enabled	Turn on if your site uses a PROXY server.	
	Default setting	off
	Optional settings	on, off
Proxy Server	Displays the proxy server IP address.	
Proxy Port	Displays currently set proxy server port.	
Proxy User	Proxy user name.	
Proxy Password	Proxy user name's password.	

Date/Time	Description and settings	
NTP Enabled	Turns on or off the use of a network time server.	
	Default setting	on
NTP Server	Optional settings	on, off
	Displays the currently set NTP server. (1.pool.ntp.org)	
Time Zone	Displays the currently set time zone.	
	Default setting	Eastern
Date	Optional settings	"your time zone"
	Sets or displays currently set date.	
Time	Optional settings	(MM/DD/YY)
	Sets or displays current time.	
	Optional settings	00:00:00 to 23:59:59

Features	Description and settings	
B/W Jobs Color Jobs Copying Printing Scan Fax:	Controls how pricing is displayed and how these jobs are handled.	
	Note: Not all features are supported by your copier.	
	Default setting	"Varies by copier model"
	Optional settings	on, free, restrict, off
Card Revalue	N/A	
Card Display	Displays card prices rather than cash prices.	
	Default setting	off
Dual JPC	Optional settings	on or off
	Allows the vend station to communicate with a PC and a Jamex embedded application that uses JPC	
	Default setting	off
	Optional settings	on or off

Credit Options	Description and settings	
Quick Pay 1 – 3	Sets value of quick pay buttons.	
	Default setting	1, 5, and 10
	Optional settings	(Even numbers only. Up to 80.00)
Credit TX Timeout	Length of idle time before a credit transaction is automatically ended.	
	Default setting	45 (seconds)
	Optional settings	N/A
Credit Over Cell	Uses cellular network for credit transactions. Cellular modem is extra. A cellular data service is required.	
	Default setting	on
	Optional settings	on or off

Minimum Charge	Sets a minimum amount that will be charged.	
	Default setting	\$0.10
	Optional settings	\$0.00 - \$80.00

Changer	Description and settings	
Auto Tube Sense	Works with some changers to auto detect the amount of coins in each tube. This can vary by a plus or minus difference of up to 5 coins per tube.	
	Default setting	off
	Optional settings	on or off
Tube Display	Displays the current tube total if the coin return is pressed while there is no credit.	
	Default setting	on
	Optional settings	on or off
Auto Return	Change is returned when the remaining credit falls below the cost per copy. This is best suited for single price installations.	
	Default setting	on
	Optional settings	on or off
Reset Count (1—6)	Sets the amount of coins that will be reported to be in each change tube after the “Reset Tube” function has been performed. The number of reset counts to choose from will vary based on the changer's configuration.	
	Default setting	0
	Optional settings	0 – 999

Reporting	Description and settings	
Reports Enabled	Used to disable reporting. If only the “From Name” is displayed, the reporting feature was not purchased.	
	Default setting	off
	Optional settings	on or off
Use Jamex Mail server	Sets the reporting email server to use jamexmail.com	
	Default setting	off
	Optional settings	on or off
Server URL	The URL of the SMTP server you'd like to use.	
Server Port	The port your email provider recommends for use.	
Server User	The user name of the email account you've set up.	
Server Pass:	The password of the email account you've set up	
From Address	The user of the email account you've set up	
From Name	Name is used when exporting meter readings to a USB drive or on emailed reports.	
To Addresses	Email addresses that get reports(separated by semicolon)	

Reporting	Description and settings	
Report Power On	Emails a report each time the unit is power cycled.	
	Default setting	off
	Optional settings	on or off
Report Update	Emails a report each time firmware has been updated.	
	Default setting	on
	Optional settings	on or off
Report Bypass	Emails a report each time the bypass key is used and includes the cash value of the job.	
	Default setting	on
	Optional settings	on or off
Report Errors	Emails a report if an MDB device reports an error	
	Default setting	on
	Optional settings	on or off
Report Cashout	Emails a report of the meters prior to reset at cashout.	
	Default setting	on
	Optional settings	on or off
Report No Change	Emails a tube inventory report when for low change.	
	Default setting	on
	Optional settings	on or off
Report # Bills	If a value is set here, a report is emailed when the stored bills equals that number. This meter is reset at cashout.	
	Default setting	0000
	Optional settings	0000—9999
Share data with Jamex	Lets you share your emailed reports with Jamex and expands the ability for Jamex to assist, if On is selected.	
	Default setting	off
	Optional settings	on or off
Report Date	Sets a specific day of the month to send a meter report.	
	Default setting	Not Set (= 00)
	Optional settings	00—31
Report Day	Sets a specific day or days of the week to email a report.	
	Default setting	Not Set (= None)
	Optional settings	None, Sat/Sun, Mon-Fri, Sunday, Monday, Tuesday, Wednesday, Thursday, Friday or Saturday. For a daily report, only set report hr.
Report Hour	Sets a specific hour to email a meter report.	
	Default setting	00
	Optional settings	00—23
Send Test	Press "Enter" to send a report to verify server settings.	

		Description and settings	
Custom Messages	Up to six custom messages can shown on the display. They are programmed as three two line sets and appear prior to the pricing information and after the escrow information. Up to 16 characters are available per line and two lines are displayed at one time. The text is left justified so add spaces to the left if centering is desired. These must be programmed using the Web Tool. See pages 5 and 6 for details.		
	Default setting	N/A	
	Optional settings	Examples:	<div style="border: 1px solid black; padding: 5px; text-align: center; margin-bottom: 5px;">Deposit Up To 5.00</div> <div style="border: 1px solid black; padding: 5px; text-align: center; margin-bottom: 5px;">Start a credit transaction</div> <div style="border: 1px solid black; padding: 5px; text-align: center; margin-bottom: 5px;">by selecting a a Quick Pay</div> <div style="border: 1px solid black; padding: 5px; text-align: center; margin-bottom: 5px;">button on the card reader</div> <div style="border: 1px solid black; padding: 5px; text-align: center;">B/W Copies 0.10</div>

		Description and settings	
Timeouts			
Timeout Length	Duration of minutes credit remains on the display before being returned or deducted.		
	Default setting	00:00:00	
	Optional settings	00:00:00 – 29:59:59	
Timeout Return	Sets whether to keep or return the remaining cash funds at the end of the “Timeout Length” setting.		
	Default setting	on (change returned)	
	Optional settings	on or off	

Enhanced Bypass	Description and settings	
	See the User's Guide for steps to use this option.	
Key Enabled	Can allow or deny use of the bypass key. This is helpful if keys are lost or stolen.	
	Default setting	off = bypass key disabled
	Optional settings	on or off
Enhanced Time	Used to set a specific amount of time in minutes the vend station can be used freely when put in Enhanced Bypass Time mode.	
	Default setting	00:00:00
	Optional settings	00:00:00 – 29:59:59
Enhanced Value	Sets the unit of value used for incrementing when starting an Enhanced Bypass value mode session.	
	Default setting	\$00.05
	Optional settings	\$0.05 - \$50.00
Enhanced Enabled	Enables or disables the Enhanced Bypass features.	
	Default setting	on
	Optional settings	on or off (off = standard bypass mode.)

Most network and reporting server settings as well as the custom messages must be configured using the Web Tool and USB configuration file import. Review pages 5 and 6 to learn how to create and manage your configuration file and import/export it.

Note: If an option shown here is not displayed in your service modes, It is not needed or used by your MFP (multi functional printer) or is not part of your firmware package.

Jamex 9550 Series Vend Station Full Exterior Layout

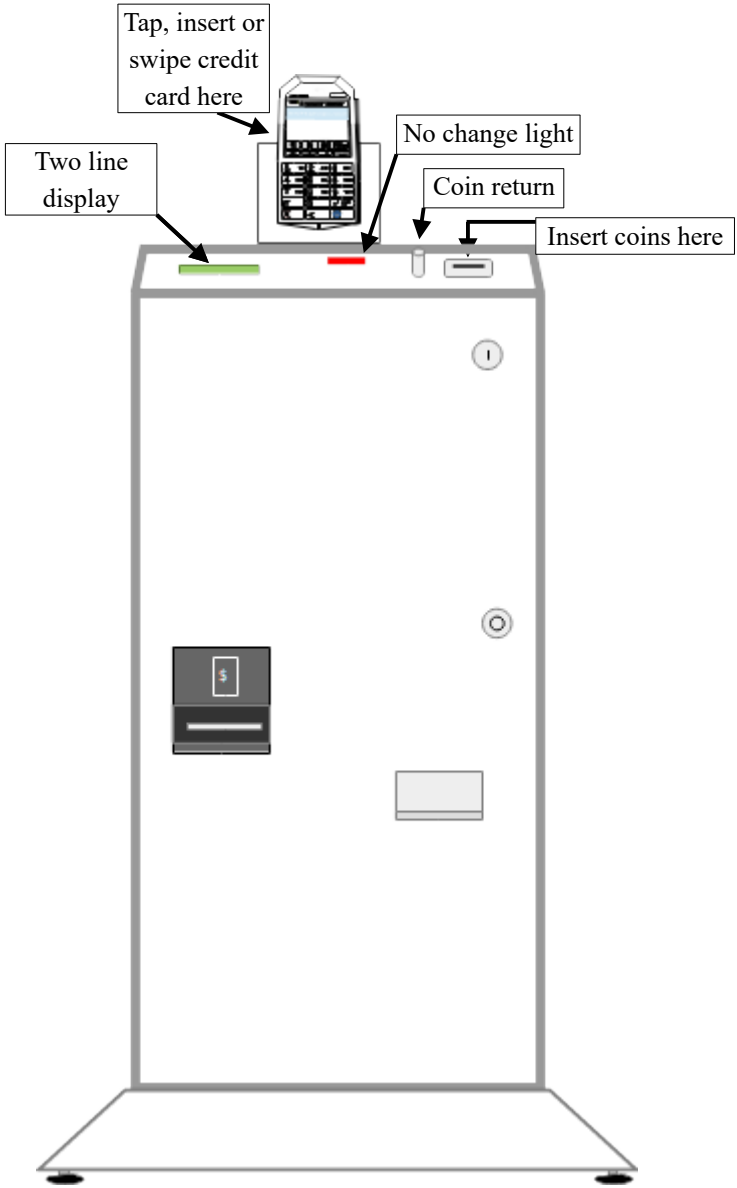

Jamex 9550 Series Vend Station Interior Layout

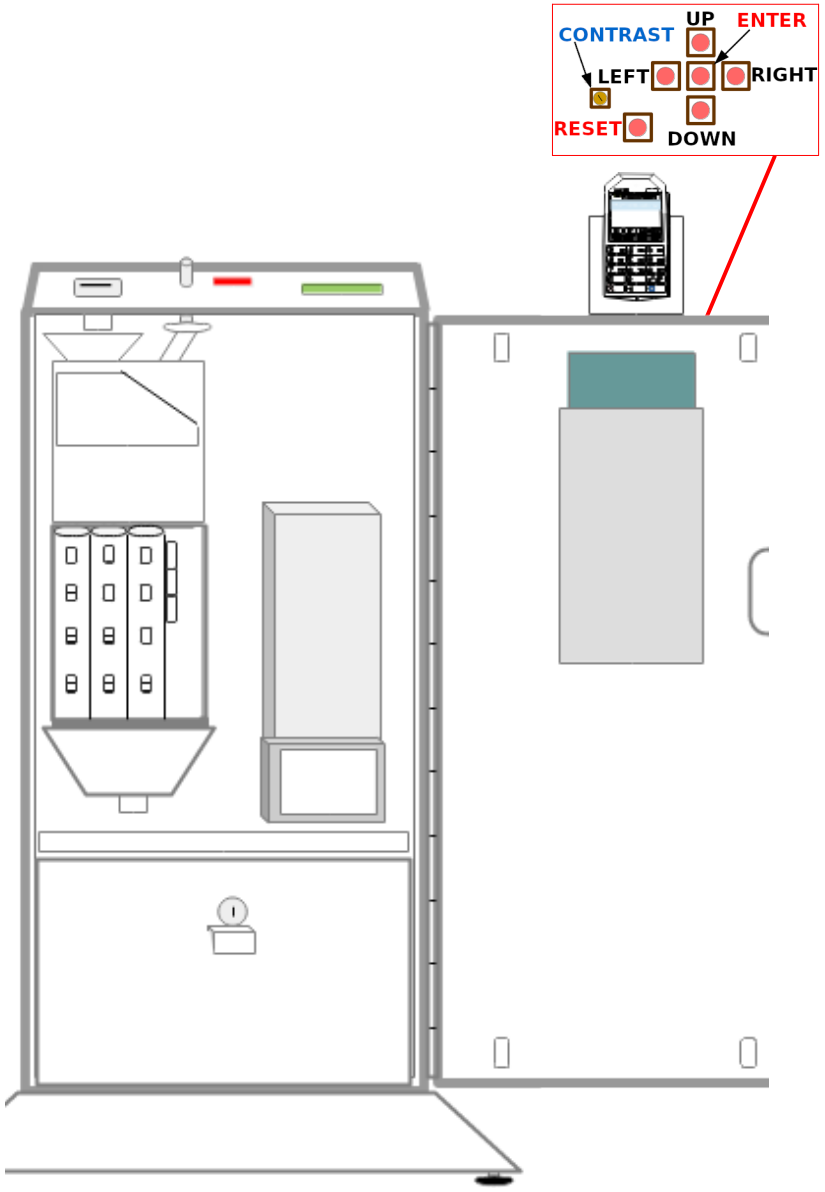

Cover Pan And Main Board Connector Locations

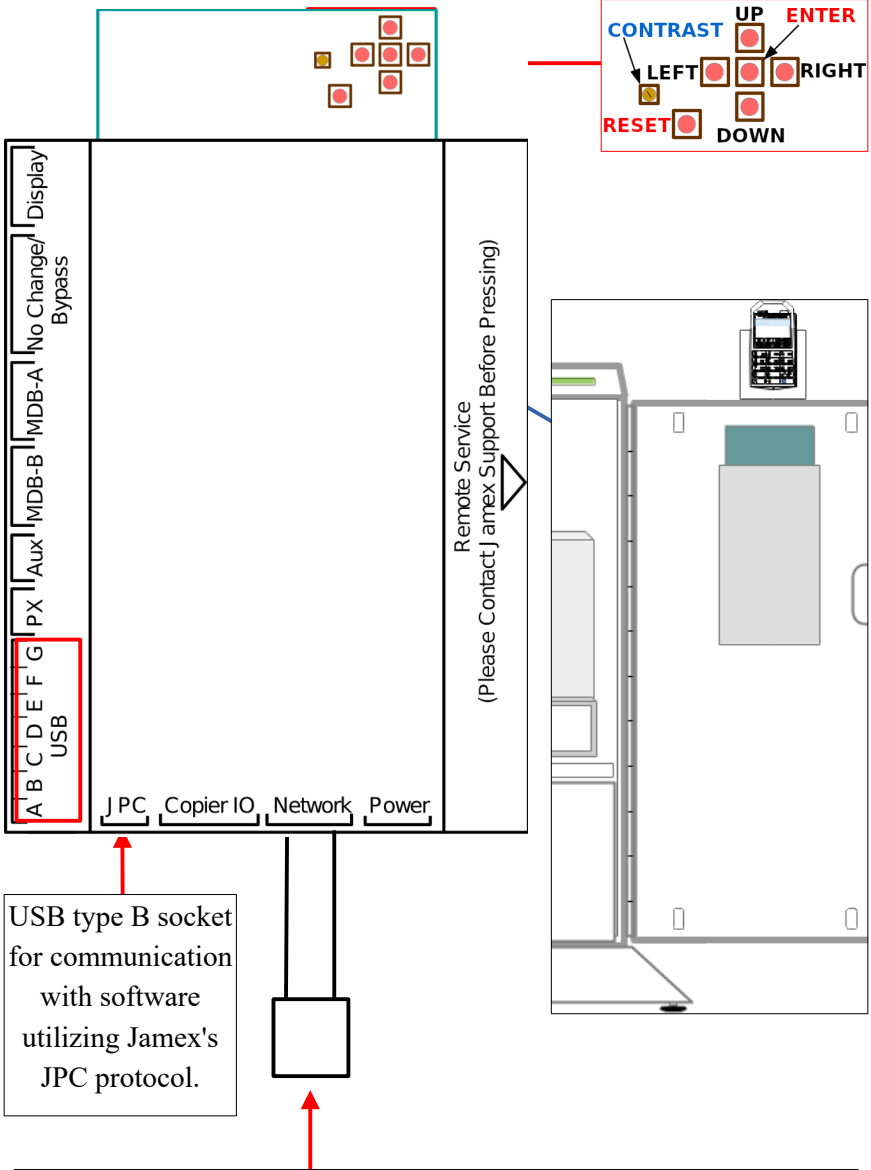

USB type B socket for communication with software utilizing Jamex's JPC protocol.

Connect your network cable here.

Verify with your IT staff that the vend station will be able to connect to the internet and allow inbound and outbound TCP traffic on ports 22, 80, and 443. If using the reporting option, also allow the email server's port. If you're using the Jamex email server, it uses port 465.

Service Mode Layout (Settings)

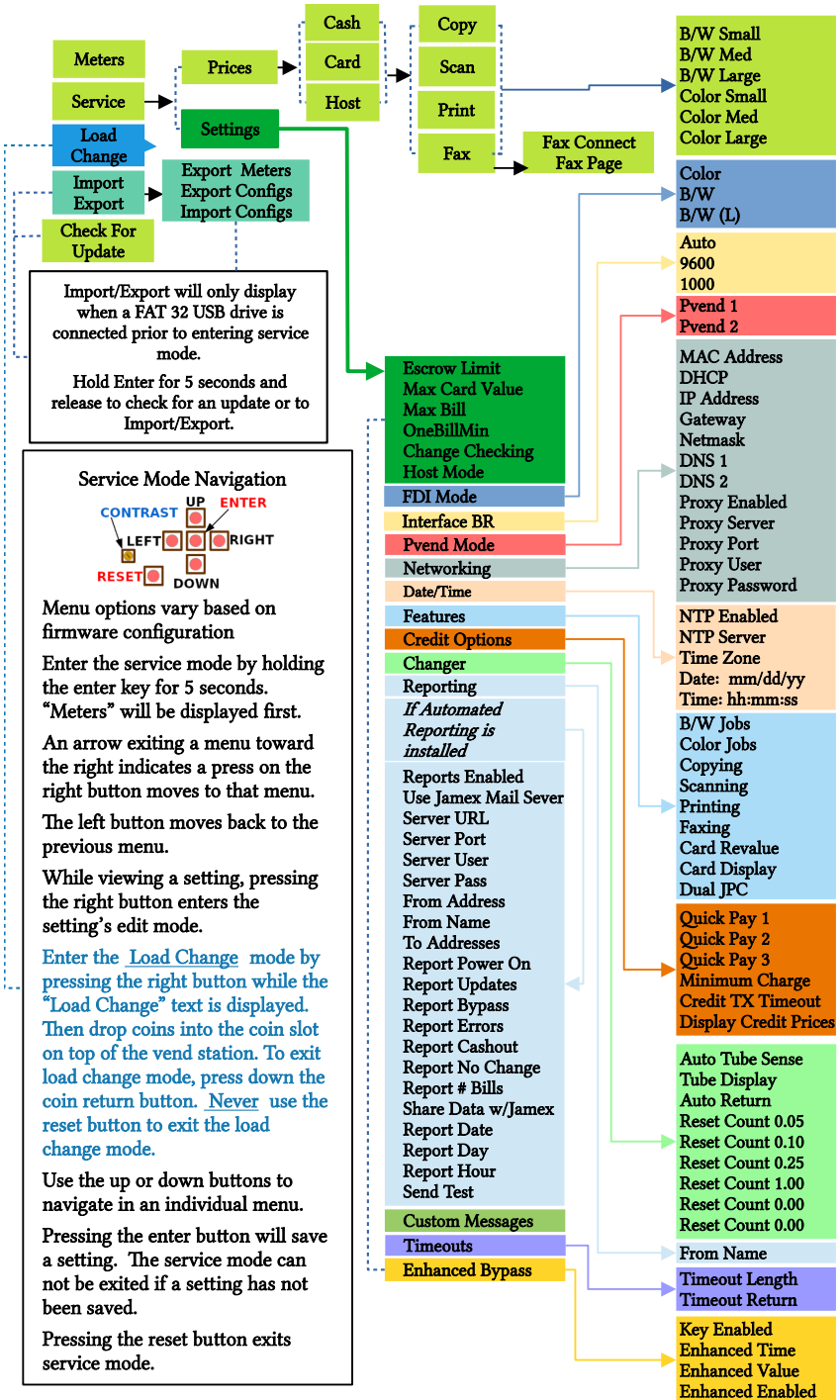

Service Mode Layout (Meters)

Meters Service Mode Navigation

Menu options vary based on firmware configuration.

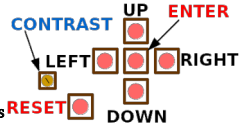

Enter the service mode by holding the enter key for 5 seconds. "Meters" will be Displayed first. An arrow exiting a menu toward the right indicates a press on the right button moves to that menu. The left button moves back to the previous menu. Use the up or down buttons to navigate in an individual menu.

While viewing a setting, pressing the right button enters the setting's edit mode. Pressing the enter button will save a setting. The service mode can not be exited if a setting has not been saved.

Do not use reset if in "Load Change Mode". Use the coin return instead.

Pressing the reset button exits service mode.

